

Rooftop Sky

EN

Installation, use and maintenance manual

24-02-2021

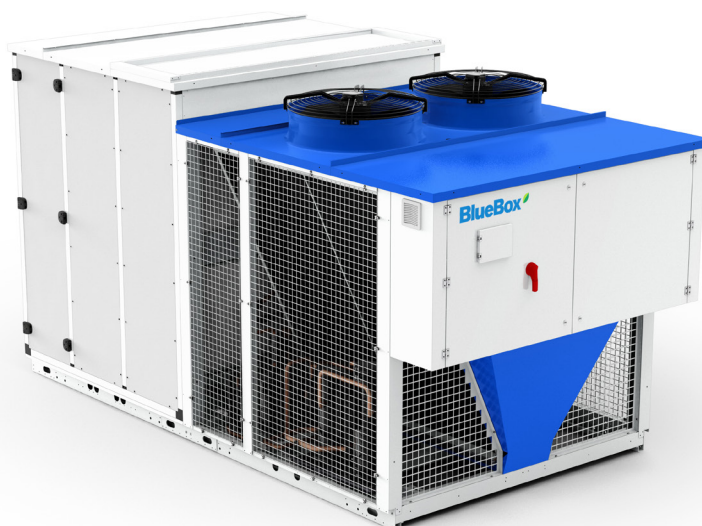

THANK YOU

Thank you for choosing our product.

It is the result of many years' experience and careful design and has been built with first-class quality materials and advanced technologies.

Declaration or certificate of conformity also guarantees that the equipment meets the requirements of the European Machinery Safety Directive.

The quality level is constantly monitored, and therefore our products are synonymous with Safety, Quality and Reliability. Changes considered necessary for product improvement may be made to the stated data at any time without any obligation to give prior notice.

Thank you again



Read this manual carefully before installing, testing or starting this unit.

Give this manual and all complementary documentation to the operator of the system who will be responsible for keeping them so they are always available if needed.



The images and drawings contained herein are examples only.

Contents

1	Introduction	6
1.1	Conformity	6
1.2	Description	6
1.2.1	<i>Symbols</i>	6
1.2.2	<i>Labels</i>	7
2	Safety	8
2.1	General safety precautions	8
2.1.1	<i>Discharge of the safety valves</i>	9
2.1.2	<i>Emergency stop</i>	10
2.2	Basic rules	11
2.2.1	<i>Limits to the use – Minimum area of the conditioned space and maximum refrigerant charge</i>	12
2.2.2	<i>Refrigerant leak detector</i>	16
2.2.3	<i>Water flow rate at the heat exchangers</i>	17
2.2.4	<i>Water composition</i>	17
2.2.5	<i>Warnings concerning flammable refrigerants</i>	18
2.3	Noise	24
2.4	Residual risks	24
2.5	Safety information on the refrigerant fluid	25
2.5.1	<i>Hazards and health consequences</i>	25
3	Receiving the product and storage	26
3.1	Reception	26
3.2	Transport	26
3.3	Handling	27
4	Product description	29
4.1	Intended use	29
4.2	Unintended use	29
4.3	Control and safety devices	30
4.4	Principles of operation	30
4.5	Structure	30
4.6	Specifications	30
4.7	Air system	31
4.7.1	<i>Internal air fans</i>	31
4.7.2	<i>Flow rate sensor for fans</i>	31
4.7.3	<i>Dirty filter sensor (optional)</i>	32
4.7.4	<i>Air filters</i>	32
4.7.5	<i>Humidifier</i>	32
4.8	Control panel	33

4.8.1	Switch the unit on and off from the display.	33
4.8.2	Switch the unit on and off from external OK signal	33
4.8.3	Change of set points	33
4.8.4	Time band setup procedure	34
4.8.5	Change language	34
4.8.6	Change date and time	34
4.9	Wiring diagram	35
5	Installation	36
5.1	Dimensions and weight	36
5.2	Installation site	36
5.3	Installation	38
5.3.1	External positioning	38
5.3.2	Fitting of rain hoods	38
5.3.3	Anti-vibration mounts	39
5.3.4	Noise attenuation	40
5.3.5	Minimum distances	40
5.4	Hydraulic connections	41
5.4.1	Hot water coil connection	41
5.4.2	Condensate drain of the internal air coil	41
5.4.3	Condensate drain of the external air coil	42
5.4.4	Connection to the humidifier	42
5.5	Electrical connections	43
5.6	Aeraulic connections	45
5.6.1	Return and supply ducts	45
5.6.2	Connection of the ducts	46
6	Commissioning	47
6.1	Preliminary operations	47
6.2	First starting	48
6.2.1	Preliminary checks	48
6.2.2	Functional tests	48
6.3	Calibration of safety components	49
6.4	Checks during operation	50
6.5	Alarms and malfunctions	51
6.5.1	General troubleshooting	51
6.6	Temporary stop	53
6.7	Stop for long periods of time	53
7	Maintenance	54
7.1	Adjustments	54
7.2	External cleaning	55

7.2.1	<i>Cleaning traditional finned coils in Cu/Al</i>	55
7.2.2	<i>Installation site cleanness</i>	56
7.3	Internal cleaning	56
7.3.1	<i>Cleaning the unit</i>	56
7.4	Periodic checks	57
7.5	Unscheduled maintenance	58
7.5.1	<i>Special work</i>	58
8	Decommissioning	59

1 INTRODUCTION

1.1 Conformity

With regard to relevant regulations and directives, see the declaration of conformity that is an integral part of the manual.

1.2 Description

1.2.1 Symbols

A description of the main symbols used in this manual and on the labels affixed to the unit is given below.



Danger symbol; take extreme care.



Danger symbol; moving mechanical parts.



Danger symbol; live parts.



Warning symbol; important information



Note symbol; suggestions and advice



Danger sign: flammable gas.

1.2.2 Labels

For the constructional features, available models and technical data, please refer to the Technical Catalogue.

The model, serial number, features, power supply voltage and so on are shown on the labels affixed to the unit (the following illustrations are shown only as an example).

LOGO		CE	
[]			
Tipo refrigerante Type réfrigérant Refrigerant type Kältemitteltyp	GWP	IP quadro elettrico IP tableau électrique IP electrical panel IP schaltschrank	Matricola Numéro de série Serial number Seriennummer
[]	[]	[]	[]
Max. Corrente assorbita Max. Courant absorbé Max. Absorbed current Max. Stromaufnahme		Max. Corrente di spunto Max. Courant de démarrage Max. Inrush current Max. Anlaufstrom	
[]		[]	
Tensione-Fasi-Frequenza Tension-Phases-Fréquence Voltage-Phases-Frequency Spannung-Phasen-Frequenz		Tensione circuiti ausiliari Tension circuit auxiliaires Auxiliary circuit voltage Steuerspannung	
[]		[]	
Numero circuiti refrigerante Nombre circuits réfrigérant Refrigerant circuit number Anzahl der Kältekreise		Gruppo Fluido Groupe Fluides Fluid Group Fluidgruppe	
[]		[]	
TS temperatura min/max ramo: TS temperature min/max branche: TS temperature min/max branch: TS temperatur min/max zweig:		PS Press. max refrigerant ramo: PS Press. max réfrigérant branche: PS Press. max refrigerant branch: PS Druck max kältemittel zweig:	
[]		[]	
Press. massima circuito idraulico Press. Maxi circuit hydraulique Max. hydraulic circuit pressure Max. zulässiger Druck im Wassersystem		Data di produzione Date de production Date of manufacture Herstellungsdatum	
[]		[]	
Carica refrigerante per circuito(kg)/Charge réfrigérant par circuit(kg) Refrigerant charge on circuit (kg)/Kältemittel Füllmenge (kg/Leitlauf)(kg)			
C1	C2	C3	C4
[]	[]	[]	[]
TON di CO2 equivalente/TON equivalent CO2/TON of CO2 equivalent/TON CO2-äquivalent			
[]			
Contiene gas fluorurati ad effetto serra disciplinati dal protocollo di Kyoto/Contient des gaz à effet de serre fluorés relevant du protocole de Kyoto/Contains fluorinated greenhouse gases covered by the Kyoto Protocol/Enthält vom Kyoto-Protokoll erfasste fluorierte Treibhausgase.			
Manufactured by VAT IT 02481290282			

LOGO		CE	
Mod. []			
		Ser. nr. []	
Tipo refrigerante - Type réfrigérant - Refrigerant type - Kältemitteltyp []			
Manufactured by VAT IT 02481290282			



The Manufacturer adopts a continuous development policy and, in this perspective, reserves the right to make changes and improvements to the documentation and to the units without prior notice.



The Technical Catalogue, the labels placed directly on the unit and the various diagrams referred to below, must be considered an integral part of this manual.



Do not remove or alter the labels placed on the unit.

2 SAFETY

2.1 General safety precautions

Access to the area around the unit must be prevented by special guarding where this is positioned in a location that is not protected and can be reached by unqualified persons.

The equipment operator is responsible for complying with regulatory obligations.

The equipment operator is the person who has actual control over the technical operation and free access, which means the possibility of monitoring its components and their operation and the possibility of granting access to third parties.

The equipment operator has the power to decide on technical modifications, checks and repairs.

The equipment operator may give instructions to employees or to external companies for carrying out maintenance and repair operations.

Access to the unit must be granted exclusively to technicians authorised by the equipment operator.

The equipment must be installed and maintained or repaired by staff and contractors who hold a relevant certificate issued by a certification body. Within Europe, the certification body must be designated by a member state to certify compliance with the requirements laid down in Regulation (EU) No 517/2014 of the European Parliament and of the Council of 16 April 2014 on fluorinated greenhouse gases and repealing Regulation (EC) No 842/2006 Text with EEA relevance.

Any operator gaining access to the unit must be authorised and qualified as specified by Annex HH of IEC 60335-2-40:2018, by local legislations and, with respect to european standards, by EN 378-4 and EN 13133 ", additionally, they must have proper knowledge to perform all the activities required throughout the service life of the machine.

Access to the unit requires that the closing panels, where fitted, are removed.

On no account must unqualified personnel be allowed to enter the unit and no one should be allowed to enter before the power to it has been turned off.

The user can interact with the unit only through the control and external OK signals.

Only authorised knowledgeable personnel may access the unit in compliance with safety in the workplace regulations. At European level, refer to Council Directive 89/391/EEC of 12 June 1989 on the introduction of measures to encourage improvements in the health and safety of workers at work.

Also, knowledge and understanding of the manual are indispensable for reducing risks and for improving the health and safety of workers.

The operator must know what to do when faced with possible anomalies, malfunctions or conditions of danger to himself or others, and in any case, he must comply with the following instructions:



Stop the unit immediately by using the emergency device.



Do not do anything that goes beyond your duties and technical knowledge.



Inform the manager immediately and do not take personal initiatives.



Before carrying out any work on the unit, make sure you have turned off the power supply to it. Refer to the section on maintenance work.



Before work is started on the unit: check for potentially flammable atmospheres; Make sure there are no possible ignition sources comply with the requirements specified by Annex HH of standard IEC 60335-2-40:2018, by local legislations, and, with respect to european standards, by EN 378-4 and EN 13133", and by existing local regulations.



In units with capacitors and/or inverters, certain components can remain live for several minutes even after having turned off the main switch.

Wait 10 minutes before working on the electrical parts of the unit.



Circuits supplied from external sources (made with orange cable) can remain live even after the power supply to the unit has been turned off.



Work on the unit only if there is sufficient lighting for the type of work to be carried out.

Failure to comply with the instructions in this manual and any modifications made to the unit without prior written consent, will immediately void the warranty.



The law regulating the use of stratospheric ozone depleting substances prohibits the release of refrigerant gases into the environment and obliges owners to recover and return them to the dealer or take them to special collection centres at the end of their operational life.

The refrigerant contained in the refrigerant circuit is included among the substances subject to special control regulations provided for by law and must therefore be disposed of as indicated above.

Particular care should be taken during maintenance operations in order to reduce refrigerant leaks as much as possible.

2.1.1 Discharge of the safety valves

If present on the refrigerant circuit, installation requirements and/or national regulations lay down that the discharge of the safety valves must be routed to the outside.

The conveying must be done with a pipe whose diameter must be at least that of the valve outlet, and the weight of the pipe must not be borne by the valve.



Always direct the discharge to areas where the jet cannot cause harm to anyone.



Risk of burns following contact with hot and cold parts.



any material exhausted from the safety valves must be conveyed using pipes in compliance with the national and/or European directives: the exhaust point must not be close to trap-doors, manhole covers and any other opening where refrigerant may be contained; exhausted material must not be conveyed close to fresh air inlets, doors or similar openings; exhausted material must not be conveyed close to ignition sources, as defined in standard EN378-2.

It is responsibility of the installer to carry out a flammability risk assessment and a classification of the danger zone at the site of installation, as required by standard EN378-3 and/or the national regulations in place.

2.1.2 Emergency stop

In case of emergency, an immediate stop is carried out using the red disconnecting switch/master switch on the electrical control panel by turning it to 0. When it is turned to 0, the disconnecting switch turns off the power to the whole unit.



The main disconnect switch/master switch, used to electrically isolate the unit, is also intended for use as an emergency device and it is only in an emergency that it should be used to stop the unit.

Except the case of an emergency stop, the unit must be stopped using its control software.

2.2 Basic rules

All the units are designed and built in compliance with Directive 2014/68/EU of the European Parliament and of the Council of 15 May 2014 on the approximation of the laws of the Member States relating to pressure equipment.

To ensure maximum safety, in order to prevent possible risks, follow the instructions below:

- this product contains pressurised vessels, live components, moving mechanical parts and very hot and cold surfaces that, in certain situations, can pose a risk: all maintenance work must be carried out by skilled personnel equipped with the necessary qualifications in accordance with current regulations. Before carrying out any operation, make sure that the personnel in charge has full knowledge of the documentation supplied with the unit.
- always have a copy of the documentation near the unit.
- The operations indicated in this manual must be integrated with the procedures indicated in the user instruction manuals of the other systems and devices incorporated in the unit. The manuals contain all the necessary information for safely managing the devices and the possible operating modes.
- use suitable protection (gloves, hard hat, protective glasses, safety shoes, etc.) for all maintenance or control operations carried out on the unit.
- Do not wear loose clothing, ties, chains, watches, etc., which can get caught in the moving parts of the unit.
- always use tools and protective equipment in excellent condition.
- The compressors and delivery gas pipes are at high temperature. Therefore, when working in the immediate vicinity, be careful to avoid touching any components of the unit without suitable protection.
- do not work in the discharge trajectory of the safety valves.
- if the units are positioned in unprotected places which can easily be reached by unqualified persons, suitable protection devices must be installed.
- the user must consult the installation and use system manuals, incorporated and attached to this manual.
- there may be potential risks that are not obvious. Warnings and signals are therefore displayed on the unit.
- Do not remove the warnings.

It is expressly forbidden to:

- remove or disable the safety guards;
- tamper with and/or modify, even partially, the safety devices installed on the unit.

If there are alarm warnings and consequent tripping of the safety devices, the user must call in skilled maintenance technicians to fix the problem immediately.



An accident can lead to serious injury or death.

The safety devices must be tested according to the guidelines in this manual.

The manufacturer does not assume any liability for damage/injury to persons, pets or objects arising from the re-use of individual parts of the unit for functions or assembly situations different from the original ones. Tampering with/unauthorised replacement of one or more parts of the unit is prohibited.

The use of accessories, tools or consumables other than those recommended by the Manufacturer relieves the latter from civil and criminal liability.

Deactivation and scrapping of the unit must be carried out only by suitably trained and equipped personnel.



The units do not fall within the scope of Directive 2014/34/EU of the European Parliament and of the Council, of 26 February 2014, on the approximation of the laws of the Member States relating to equipment and protective systems intended for use in potentially explosive atmospheres.



Any operator gaining access to the unit must be authorised and qualified as specified by Annex HH of IEC 60335-2-40:2018, by local legislations and, with respect to european standards, by EN 378-4 and EN 13133 ", additionally, they must have proper knowledge to perform all the activities required throughout the service life of the machine.

2.2.1 Limits to the use – Minimum area of the conditioned space and maximum refrigerant charge

Clause GG.9 of Annex GG within the standard IEC 60335-2-40:2018 (Household and similar electrical appliances - Safety - Part 2-40: Particular requirements for electrical heat pumps, air-conditioners and dehumidifiers) defines the charge limits based on the total conditioned space area and the ventilation requirements for ducted appliances using A2L refrigerants. For full details refer to the standard IEC 60335-2-40:2018.

The minimum total conditioned room area " TA_{min} " of installed appliance with refrigerant charge " m_c " (kg) shall be in accordance with following:

For cooling only units with at least one compressor with inverter

Unit	Unit without gas post heating or liquid receiver option		For units with hot gas post heating coil		Unit with gas post heating option	
	m_c	TA_{min}	m_c	TA_{min}	m_c	TA_{min}
	[kg]	m^2	[kg]	m^2	[kg]	m^2
	Circuit 1		Circuit 1		Circuit 1	
2.1	6,3	18,7	8,3	24,4	7,0	20,7
3.1	8,0	23,7	11,3	33,5	10,0	29,6
4.1	10,0	29,6	13,7	40,6	12,0	35,5
5.1	12,5	37,0	17,0	50,4	15,0	44,4
6.1	16,0	47,4	21,0	62,0	18,0	53,3
7.2	16,0	47,4	21,0	62,0	18,0	53,3
8.2	21,0	62,2	26,9	79,6	23,0	68,1
9.2	22,0	65,1	28,0	83,0	24,0	71,1
10.2	25,0	74,0	32,3	95,7	28,0	82,9
11.2	27,0	80,0	34,7	102,8	30,0	88,8
12.2	31,5	93,3	41,2	122,1	36,0	106,6

For cooling only units with all "ON / OFF" compressors

Unit	Unit without gas post heating or liquid receiver option			For units with hot gas post heating coil			Unit with gas post heating option		
	m_c		TA_{min}	m_c		TA_{min}	m_c		TA_{min}
	[kg]		m^2	[kg]		m^2	[kg]		m^2
	Circuit 1	Circuit 2		Circuit 1	Circuit 2		Circuit 1	Circuit 2	
5.2	12,5	-	37,0	16,2	-	47,9	15,0	-	44,4
6.2	16,0	-	47,4	19,9	-	58,8	18,0	-	53,3
7.2	16,0	-	47,4	19,9	-	58,8	18,0	-	53,3
9.4	11,0	11,0	32,6	14,2	14,2	42,2	13,0	13,0	38,5
10.4	13,3	13,3	39,2	16,6	16,6	49,1	15,3	15,3	45,2
11.4	13,5	13,5	40,0	16,9	16,9	50,2	15,5	15,5	45,9
12.4	16,5	16,5	48,9	20,7	20,7	61,2	19,0	19,0	56,3
14.4	16,5	16,5	48,9	20,1	20,1	59,5	19,0	19,0	56,3
15.4	16,5	16,5	48,9	20,1	20,1	59,5	19,0	19,0	56,3
16.4	20,0	20,0	59,2	24,2	24,2	71,6	23,0	23,0	68,1
18.4	21,5	21,5	63,7	26,7	26,7	79,1	25,0	25,0	74,0
19.4	21,5	21,5	63,7	26,7	26,7	79,1	25,0	25,0	74,0

For reversible units with at least one compressor with inverter

Unit	For units without hot gas post heating coil		For units with hot gas post heating coil	
	m_c	TA_{min}	m_c	TA_{min}
	[kg]	m^2	[kg]	m^2
	Circuit 1		Circuit 1	
2.1	7,0	20,7	8,3	24,4
3.1	10,0	29,6	11,3	33,5
4.1	12,0	35,5	13,7	40,6
5.1	15,0	44,4	17,0	50,4
6.1	18,0	53,3	21,0	62,0
7.2	18,0	53,3	21,0	62,0
8.2	23,0	68,1	26,9	79,6
9.2	24,0	71,1	28,0	83,0
10.2	28,0	82,9	32,3	95,7
11.2	30,0	88,8	34,7	102,8
12.2	36,0	106,6	41,2	122,1

For reversible units with all "ON / OFF" compressors

Unit	For units without hot gas post heating coil			For units with hot gas post heating coil		
	m_c [kg]		TA_{min} m ²	m_c [kg]		TA_{min} m ²
	Circuit 1	Circuit 2		Circuit 1	Circuit 2	
5.2	15,0	-	44,4	16,1	-	47,6
6.2	18,0	-	53,3	19,8	-	58,7
7.2	18,0	-	53,3	19,8	-	58,7
9.4	13,0	13,0	38,5	14,2	14,2	42,2
10.4	15,3	15,3	45,2	16,6	16,6	49,1
11.4	15,5	15,5	45,9	16,9	16,9	50,2
12.4	19,0	19,0	56,3	20,5	20,5	60,6
14.4	19,0	19,0	56,3	20,6	20,6	61,0
15.4	19,0	19,0	56,3	20,6	20,6	61,0
16.4	23,0	23,0	68,1	24,6	24,6	72,8
18.4	25,0	25,0	74,0	27,7	27,7	82,1
19.4	25,0	25,0	74,0	27,7	27,7	82,1



No zoning dampers shall be installed in the rooms considered to determine the minimum room area unless these zoning dampers can be fully opened by the control signal of the rooftop in case of a leak

If the refrigerant charge is adjusted on the field, the minimum area must be re-evaluated in order to be always above the result obtained through the following formula:

$$TA_{min} = (m_c + m_{added}) / 0.338$$

where

- m_{added} is the refrigerant charge added on the field in kg.



The sum " $m_c + m_{added}$ " must be lower than 79,8 kg for each circuit.

The minimum area according to the area of the conditioned space is shown below

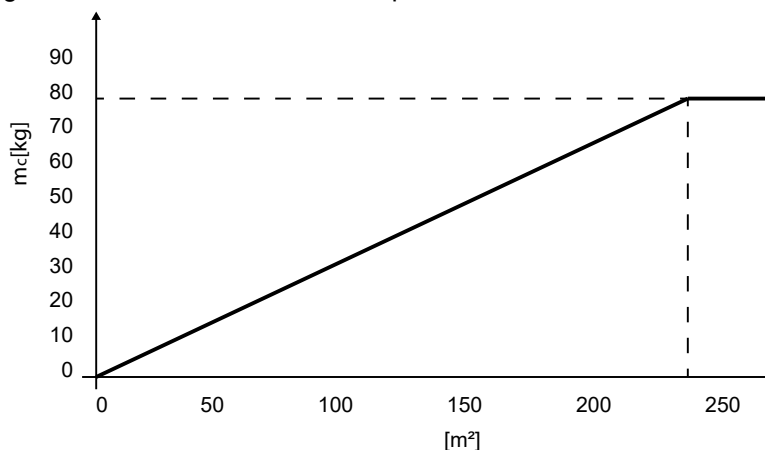

Fig. 1 Total min. installation area

The unit is equipped with a refrigerant detection system that complies with Annex LL of the IEC 60335-2-40:2018, which position has been checked according to test reported in Annex MM of IEC 60335-2-40:2018.

When the refrigerant detection system detects a leak, the following will be initiated by the unit:

- disable the compressor operation unless the compressors;
- Supply and return (if present) fan control will be set to constant airflow logic with a fix airflow value. The fans will operate continuously even if time tables are set. This in order to not let the airflow to go below " Q_{min} " (see below);
- Energize a dedicated relay in the electrical cabinet in order to fully open any external zoning dampers;
- Set the dampers (if installed on the appliance) in order to have a full intake of fresh air and a full expulsion of the return air.



External zoning dampers, if present, must be connected to this relay in order to be open when a leak is detected



Zoning dampers installed in rooms considered to determine the minimum room area must be electrically powered at all times after installation, other than when servicing, to be effective for safety.

The refrigerant detection system and controls will maintain the above action until at least 5 min after the refrigerant detection system has reset. Building fire and smoke systems may override this function.



If the leak detector detects a leak, the above operations will be initiated even if the unit is turned OFF by button, by BMS or by digital input.



In addition to what above another dedicated relay is present in the unit electrical cabinet and connected directly to the leak detector alarm. This relay can be used to monitor the leak detector alarm even in case of a unit control board fault.

The minimum circulation airflow (Q_{min}) circulated to the total conditioned space, expressed in m^3/h , must be in accordance with the following table:

For cooling only units with at least one compressor with inverter

Unit	Unit without gas post heating or liquid receiver option		For units with hot gas post heating coil		Unit with gas post heating option	
	m_c	Q_{min}	m_c	Q_{min}	m_c	Q_{min}
	[kg]	m^3/h	[kg]	m^3/h	[kg]	m^3/h
	Circuit 1		Circuit 1		Circuit 1	
2.1	6,3	1231	8,3	1613	7,0	1368
3.1	8,0	1564	11,3	2208	10,0	1954
4.1	10,0	1954	13,7	2680	12,0	2345
5.1	12,5	2443	17,0	3326	15,0	2932
6.1	16,0	3127	21,0	4095	18,0	3518
7.2	16,0	3127	21,0	4095	18,0	3518
8.2	21,0	4104	26,9	5255	23,0	4495
9.2	22,0	4300	28,0	5479	24,0	4691
10.2	25,0	4886	32,3	6315	28,0	5472
11.2	27,0	5277	34,7	6783	30,0	5863
12.2	31,5	6156	41,2	8059	36,0	7036

For cooling only units with all "ON / OFF" compressors

Unit	Unit without gas post heating or liquid receiver option			For units with hot gas post-heating or liquid receiver option			Unit with gas post heating option		
	m_c [kg]		Q_{min} m ³ /h	m_c [kg]		Q_{min} m ³ /h	m_c [kg]		Q_{min} m ³ /h
	Circuit 1	Circuit 2		Circuit 1	Circuit 2		Circuit 1	Circuit 2	
5.2	12,5	-	2443	16,2	-	3160	15,0	-	2932
6.2	16,0	-	3127	19,9	-	3881	18,0	-	3518
7.2	16,0	-	3127	19,9	-	3880	18,0	-	3518
9.4	11,0	11,0	2150	14,2	14,2	2783	13,0	13,0	2541
10.4	13,25	13,25	2590	16,6	16,6	3242	15,3	15,3	2980
11.4	13,5	13,5	2638	16,9	16,9	3312	15,5	15,5	3029
12.4	16,5	16,5	3225	20,7	20,7	4038	19,0	19,0	3713
14.4	16,5	16,5	3225	20,1	20,1	3929	19,0	19,0	3713
15.4	16,5	16,5	3225	20,1	20,1	3929	19,0	19,0	3713
16.4	20,0	20,0	3909	24,2	24,2	4723	23,0	23,0	4495
18.4	21,5	21,5	4202	26,7	26,7	5223	25,0	25,0	4886
19.4	21,5	21,5	4202	26,7	26,7	5223	25,0	25,0	4886

For reversible units with at least one compressor with inverter

Unit	For units without hot gas post heating coil		For units with hot gas post heating coil	
	m_c [kg]	Q_{min} m ³ /h	m_c [kg]	Q_{min} m ³ /h
	Circuit 1		Circuit 1	
2.1	7,0	1368	8,3	1613
3.1	10,0	1954	11,3	2208
4.1	12,0	2345	13,7	2680
5.1	15,0	2932	17,0	3326
6.1	18,0	3518	21,0	4095
7.2	18,0	3518	21,0	4095
8.2	23,0	4495	26,9	5255
9.2	24,0	4691	28,0	5479
10.2	28,0	5472	32,3	6315
11.2	30,0	5863	34,7	6783
12.2	36,0	7036	36,0	7036

For reversible units with all "ON / OFF" compressors

Unit	For units without hot gas post heating coil			For units with hot gas post heating coil		
	m_c [kg]		Q_{min} m ³ /h	m_c [kg]		Q_{min} m ³ /h
	Circuit 1	Circuit 2		Circuit 1	Circuit 2	
5.2	15,0	-	2932	16,1	-	3140
6.2	18,0	-	3518	19,8	-	3875
7.2	18,0	-	3518	19,8	-	3875
9.4	13,0	13,0	2541	14,2	14,2	2783
10.4	15,3	15,3	2980	16,6	16,6	3239
11.4	15,5	15,5	3029	16,9	16,9	3311
12.4	19,0	19,0	3713	20,5	20,5	3999
14.4	19,0	19,0	3713	20,6	20,6	4028
15.4	19,0	19,0	3713	20,6	20,6	4028
16.4	23,0	23,0	4495	24,6	24,6	4803
18.4	25,0	25,0	4886	27,7	27,7	5416
19.4	25,0	25,0	4886	27,7	27,7	5416



Whenever the flow, measured by the differential air pressure transducer, falls below the values reported in the table above, the airflow alarm from differential pressure transducer will be displayed on the unit control and the unit will be stopped.

The supply and return air shall be directly ducted to the conditioned space. Open areas such as false ceilings shall not be used as a return air duct.

2.2.2 Refrigerant leak detector



This unit is equipped with a refrigerant leak detector for safety.
To be effective, the unit must be electrically powered at all times after installation, other than when servicing.

A refrigerant leak detector is installed in the unit between the supply coil and the supply fan(s).

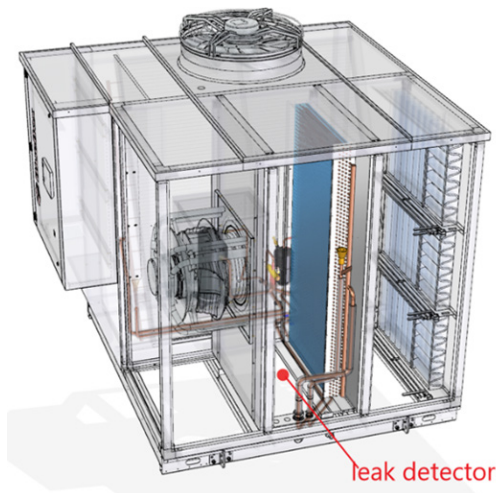

This device allows immediate detection of refrigerant leaks in order to start what reported in the above paragraph "Limit to the use – This device allows immediate detection of refrigerant leaks in order to start what reported in the above paragraph "Limit to the use – Minimum area required and maximum refrigerant charge".



The detector has an internal self-testing routine. If this routine detects a fault the unit control will automatically modify the supply and return (if present) fan control in order to set a constant airflow logic with a fix airflow value. This in order to not let the airflow to go below Q_{min} as defined in the paragraph "Limit to the use – Minimum area required and maximum refrigerant charge". The fans will operate continuously even if time tables are set, in order to have always the minimum required airflow.



In the unlike event that the airflow is not able to reach the minimum airflow level " Q_{min} " and the leak detector is faulty, a dedicated relay in the electrical cabinet will be energized. **This signal must be used to warn the user that the airflow is reduced** (e.g. a buzzer and a flashing light).



The leak detector is connected to the unit control via Modbus. In the unlike event that the leak detector goes offline, he will keep the ability to detect a leak and to communicate it to the unit control through a digital input. Therefore this case will be managed as a leak detector fault and so the unit control will operate as described in the first informative point of this paragraph.



Once the gas alarm of the leak detector system is released, the output is not reset even if the gas concentration decreases. After detecting and repairing the leak spot, a manual reset of the alarm can be operated. To reset the alarm output turn the power supply to the gas sensor off and on (e.g. disconnecting and reconnecting its cable), if the alarm output will not be reset after this operation, it means that leak has exceeded 10000 ppm, and the gas sensor has to be replaced.



The gas sensing part of the sensor has a designed life of 10 years. A countdown is set inside the detector control and read by the unit control.
Six months before the expire of the countdown a warning message will appear on the unit HMI. If the calibration will not be performed in time a warning message will appear on the unit HMI and the unit control will operate as in case of a leak detector fault (see first informative point of this paragraph).

2.2.3 Water flow rate at the heat exchangers

It is necessary to ensure that the water flow rate during operation is no higher than 1.5 times and no lower than 0.5 times the nominal flow rate of the unit stated in the Technical Catalogue.



In any case, refer to the specific Technical Catalogue for the allowed conditions for water flow in and out of the exchangers.

2.2.4 Water composition

Dissolved substances in the water can cause corrosion in the heat exchangers.

It is mandatory to make sure the parameters of the water comply with the following table:

Description	Values
Total hardness	2,0 ÷ 6,0 °f
Langelier index	- 0,4 ÷ 0,4
pH	7,5 ÷ 8,5
Electrical conductivity	10÷500 µS/cm
Organic elements	-
Hydrogen carbonate (HCO ₃ ⁻)	70 ÷ 300 ppm
Sulphates (SO ₄ ²⁻)	< 50 ppm
Hydrogen carbonate / Sulphates (HCO ₃ ⁻ /SO ₄ ²⁻)	> 1
Chlorides (Cl ⁻)	< 50 ppm
Nitrates (NO ₃ ⁻)	< 50 ppm
Hydrogen sulphide (H ₂ S)	< 0,05 ppm
Ammonia (NH ₃)	< 0,05 ppm
Sulphites (SO ₃), free chlorine (Cl ₂)	< 1 ppm
Carbon dioxide (CO ₂)	< 5 ppm
Metal cations	< 0,2 ppm
Manganese ions (Mn ⁺⁺)	< 0,2 ppm
Iron ions (Fe ²⁺ , Fe ³⁺)	< 0,2 ppm
Iron + Manganese	< 0,4 ppm
Phosphates (PO ₄ ³⁻)	< 2 ppm
Oxygen	< 0,1 ppm

ppm = mg/l

The use of water with values above the limits stated in the table will immediately void the warranty.

It is mandatory to include a system for eliminating possible organic substances in the water that could pass through the filter and settle in the heat exchangers, which would lead to malfunctioning and/or breakage over time.

The use of water containing organic substances will immediately void the warranty.

2.2.5 Warnings concerning flammable refrigerants



Units with mildly flammable refrigerants (A2L), such as R32, shall be installed in accordance with the European standards and regulations and with the local regulations, where applicable.



The information below is provided in accordance with standard IEC 60335-2-40:2018 and its annexes and clauses (here in after “Annex” and “Clause”) and it has been taken from the English version of the standard, which is the document to be referenced.



(Annex DD.2) Do not use means to accelerate the defrosting process or to clean, other than those recommended by the manufacturer.



The external unit shall be stored in a room without continuously operating ignition sources (for example: open flames, an operating gas appliance or an operating electric heater).



Do not pierce or burn.



Be aware that refrigerants may not contain an odour.



(Annex DD.3.3) Qualification of workers

Any operation concerning the installation, maintenance, repair, disassembly and dismantling of the unit shall be carried out by qualified personnel, in accordance with Annex HH to standard IEC 60335-2-40:2018, who hold a valid certificate in compliance with the existing standards.

The above-mentioned operations include:

- breaking into the refrigerating circuit;
- opening of sealed components;
- opening of ventilated enclosures.

Work shall be undertaken under a controlled procedure so as to minimise the risk of a flammable gas or vapour being present while the work is being performed.



(Annex DD.4) Information on servicing



(Annex DD.4.2) Checks to the area

Prior to beginning work on systems containing flammable refrigerants, safety checks in the area are necessary to ensure that the risk of ignition is minimised. For repair to the refrigerating system, DD.4.3 to DD.4.7 shall be completed prior to conducting work on the system.



(Annex DD.4.3) Work procedure

Work shall be undertaken under a controlled procedure so as to minimise the risk of a flammable gas or vapour being present while the work is being performed.



(Annex DD.4.4) General work area

All maintenance staff and others working in the local area shall be instructed on the nature of the work being carried out. Work in confined spaces shall be avoided.



(Annex DD.4.5) Checking for presence of refrigerant

The area shall be checked with an appropriate refrigerant detector prior to and during work, to ensure the technician is aware of potentially toxic and flammable atmospheres.

Ensure that the refrigerant or leak detection equipment being used is suitable for use with the refrigerant applicable to the unit, i.e. non-sparking, adequately sealed or intrinsically safe.



(Annex DD.4.6) Presence of fire extinguisher

If any hot work is to be conducted on the unit requiring an increase in the temperature of parts of the unit (e.g. brazing), appropriate fire extinguishing equipment shall be available to hand. Have a dry powder or CO2 fire extinguisher adjacent to the refrigerant charging area.



(Annex DD.4.7) No ignition sources

No person carrying out work in relation to a unit shall use any sources of ignition in such a manner that it may lead to the risk of fire or explosion. All possible ignition sources, including cigarette smoking, should be kept sufficiently far away from the site of installation, repairing, removing and disposal of the unit, during which flammable refrigerant can possibly be released to the surrounding space. Prior to work taking place, the area around the unit is to be surveyed to make sure that there are no flammable hazards or ignition risks. "No Smoking" signs shall be displayed.



(Annex DD.4.8) Ventilated area

Ensure that the area is in the open or that it is adequately ventilated before breaking into the system or conducting any hot work. A degree of ventilation shall continue during the period that the work is carried out. The ventilation should safely disperse any released refrigerant and preferably expel it externally into the atmosphere.



(Annex DD.4.9) Checks to the refrigerating equipment

Where electrical components are being changed, they shall be fit for the purpose and to the correct specification. At all times the manufacturer's maintenance and service guidelines shall be followed. If in doubt consult the manufacturer's technical department for assistance.

The following checks shall be applied to installations using flammable refrigerants (some parts are only applicable to refrigerant containing units or components installed inside the building):

- the charge size is in accordance with the room size within which the refrigerant containing parts are installed;
- the ventilation machinery and outlets are operating adequately and are not obstructed;
- marking to the unit and components continues to be visible and legible. Markings and signs that are illegible shall be corrected;
- refrigeration pipe or refrigerant containing components are installed in a position where they are unlikely to be exposed to any substance which may corrode refrigerant containing components, unless the components are constructed of materials which are inherently resistant to being corroded or are suitably protected against being so corroded.



(Annex DD.4.10) Checks to electrical components

Repair and maintenance to electrical components shall include initial safety checks and component inspection procedures. If a fault exists that could compromise safety, then no electrical supply shall be connected to the circuit until it is satisfactorily dealt with. If the fault cannot be corrected immediately but it is necessary to continue operation, an adequate temporary solution shall be used. This shall be reported to the owner of the unit so all parties are advised.

Initial safety checks shall include:

- that capacitors are discharged: this shall be done in a safe manner to avoid possibility of sparking;
- that no live electrical components and wiring are exposed while charging, recovering or purging the system;
- that there is continuity of earth bonding.



(Annex DD.5) Repairs to sealed components



(Annex DD.5.1)

During repairs to sealed components, all electrical supplies shall be disconnected from the unit being worked upon prior to any removal of sealed covers, guards, etc.

If it is absolutely necessary to have an electrical supply to the unit during servicing, then a permanently operating form of refrigerant leak detection shall be located at the most critical point to warn of a potentially hazardous situation.



(Annex DD.5.2)

Particular attention shall be paid to the following to ensure that by working on electrical components, the casing is not altered in such a way that the level of protection is affected.

This shall include damage to cables, excessive number of connections, terminals not made to original specification, damage to seals, incorrect fitting of glands, etc.

Ensure that apparatus is mounted securely.

Ensure that seals or sealing materials have not degraded such that they no longer serve the purpose of preventing the ingress of flammable atmospheres. Replacement parts shall be in accordance with the manufacturer's specifications.



(Annex DD.5) Repairs to intrinsically safe components

Do not apply any permanent inductive or capacitance loads to the circuit without ensuring that this will not exceed the permissible voltage and current permitted for the equipment in use.

Intrinsically safe components are the only types that can be worked on while live in the presence of a flammable atmosphere. The test apparatus shall be at the correct rating.

Replace components only with parts specified by the manufacturer. Other parts may result in the ignition of refrigerant in the atmosphere from a leak.



(Annex DD.7) Cabling

Check that cabling will not be subject to wear, corrosion, excessive pressure, vibration, sharp edges or any other adverse environmental effects. The check shall also take into account the effects of ageing or continual vibration from sources such as compressors or fans.



(Annex DD.8) Detection of flammable refrigerants

Under no circumstances shall potential sources of ignition be used in the searching for or detection of refrigerant leaks. A halide torch (or any other detector using a naked flame) shall not be used.

The following leak detection methods are deemed acceptable for systems containing flammable refrigerants.

Electronic leak detectors shall be used to detect flammable refrigerants, but the sensitivity may not be adequate, or may need re-calibration (detection equipment shall be calibrated in a refrigerant-free area). Ensure that the detector is not a potential source of ignition and is suitable for the refrigerant used. The leak detection system shall be set at a percentage of the refrigerant LFL and it shall be calibrated to the refrigerant employed; the appropriate percentage of gas (25% maximum) shall be confirmed.

Leak detection fluids are suitable for use with most refrigerants but the use of detergents containing chlorine shall be avoided as the chlorine may react with the refrigerant and corrode the copper pipe-work.

Note. Examples of leak detection fluids are:

- bubble method;
- fluorescent method agents.

If a leak is suspected, all naked flames shall be removed/extinguished.

If a leakage of refrigerant is found which requires brazing, all of the refrigerant shall be recovered from the system, or isolated (by means of shut off valves) in a part of the system remote from the leak. Removal of refrigerant shall be according to Annex DD.9.



(Annex DD.9) Removal and evacuation

When breaking into the refrigerant circuit to make repairs – or for any other purpose – conventional procedures shall be used. However, it is important that best practice is followed since flammability is a consideration.

The following procedure shall be adhered to:

- remove refrigerant;
- purge the circuit with inert gas (optional for A2L);
- evacuate (optional for A2L);
- open the circuit by cutting or brazing.

The refrigerant charge shall be recovered into the correct recovery cylinders. For units containing flammable refrigerants other than A2L the system shall be “flushed” with OFN to render the unit safe. This process may need to be repeated several times. Compressed air or oxygen shall not be used for purging refrigerant systems.

For units containing flammable refrigerants, other than A2L refrigerants, refrigerants purging shall be achieved by breaking the vacuum in the system with oxygen-free nitrogen and continuing to fill until the working pressure is achieved, then venting to atmosphere, and finally pulling down to a vacuum. This process shall be repeated until no refrigerant is within the system. When the final oxygen-free nitrogen charge is used, the system shall be vented down to atmospheric pressure to enable work to take place. This operation is absolutely vital if brazing operations on the pipe-work are to take place.



(Annex DD.10) Charging procedures

In addition to conventional charging procedures, the following requirements shall be followed.

- Ensure that contamination of different refrigerants does not occur when using charging equipment. Hoses or lines shall be as short as possible to minimise the amount of refrigerant contained in them.
- Cylinders shall be kept in an appropriate position according to the instructions.
- Ensure that the refrigerating system is earthed prior to charging the system with refrigerant.
- Label the system when charging is complete (if not already).
- Extreme care shall be taken not to overfill the refrigerating system.

Prior to recharging the system it shall be pressure-tested with the appropriate purging gas. The system shall be leak-tested on completion of charging but prior to commissioning. A follow up leak test shall be carried out prior to leaving the site.



(Annex DD.11) Decommissioning

Before carrying out this procedure, it is essential that the technician is completely familiar with the unit and all its detail. It is recommended good practice that all refrigerants are recovered safely. Prior to the task being carried out, an oil and refrigerant sample shall be taken in case analysis is required prior to re-use of reclaimed refrigerant.

- a) Become familiar with the equipment and its operation.
- b) Isolate system electrically.
- c) Before attempting the procedure, ensure that:
 - mechanical handling equipment is available, if required, for handling refrigerant cylinders;
 - all personal protective equipment is available and being used correctly;
 - the recovery process is supervised at all times by a competent person;
 - Label the system when charging is complete (if not already).
 - recovery equipment and cylinders conform to the appropriate standards.

-
- d) Pump down refrigerant system, if possible.
 - e) If a vacuum is not possible, make a manifold so that refrigerant can be removed from various parts of the system.
 - f) Make sure that cylinder is situated on the scales before recovery takes place.
 - g) Start the recovery machine and operate in accordance with instructions.
 - h) Do not overfill cylinders (no more than 80 % volume liquid charge).
 - i) Do not exceed the maximum working pressure of the cylinder, even temporarily.
 - j) When the cylinders have been filled correctly and the process completed, make sure that the cylinders and the equipment are removed from site promptly and all isolation valves on the equipment are closed off.
 - k) Recovered refrigerant shall not be charged into another refrigerating system unless it has been cleaned and checked.



(Annex DD.12) Labelling

Equipment shall be labelled stating that it has been de-commissioned and emptied of refrigerant. The label shall be dated and signed. For appliances containing flammable refrigerants, ensure that there are labels on the equipment stating the equipment contains flammable refrigerant.



(Annex DD.13) Recovery

When removing refrigerant from a system, either for servicing or decommissioning, it is recommended good practice that all refrigerants are removed safely.

When transferring refrigerant into cylinders, ensure that only appropriate refrigerant recovery cylinders are employed. Ensure that the correct number of cylinders for holding the total system charge are available. All cylinders to be used are designated for the recovered refrigerant and labelled for that refrigerant (i.e. special cylinders for the recovery of refrigerant). Cylinders shall be complete with pressure-relief valve and associated shut-off valves in good working order. Empty recovery cylinders are evacuated and, if possible, cooled before recovery occurs.

The recovery equipment shall be in good working order with a set of instructions concerning the equipment that is at hand and shall be suitable for the recovery of flammable refrigerants. In addition, a set of calibrated weighing scales shall be available and in good working order. Hoses shall be complete with leak-free disconnect couplings and in good condition. Before using the recovery machine, check that it is in satisfactory working order, has been properly maintained and that any associated electrical components are sealed to prevent ignition in the event of a refrigerant release. Consult manufacturer if in doubt.

The recovered refrigerant shall be returned to the refrigerant supplier in the correct recovery cylinder, and the relevant waste transfer note arranged. Do not mix refrigerants in recovery units and especially not in cylinders.

If compressors or compressor oils are to be removed, ensure that they have been evacuated to an acceptable level to make certain that flammable refrigerant does not remain within the lubricant. The evacuation process shall be carried out prior to returning the compressor to the suppliers. Only electric heating to the compressor body shall be employed to accelerate this process.

When oil is drained from a system, it shall be carried out safely.

2.3 Noise

The starting of the unit, with activation of its components, emits a noise whose intensity varies depending on the operating level.

The correct location choice and the correct installation prevent the unit causing annoying noise due to resonances, reflections and vibrations.

2.4 Residual risks

The unit uses technical means suitable for protecting people, animals and things against hazards that cannot reasonably be eliminated or sufficiently reduced through design.

The presence of an operator is not required for normal operation of the unit. The change from the "OFF" state to the "ON" state, and vice versa, of the unit can be carried out remotely or through the display, without having to enter areas at risk.

Access restriction is part of correct installation to eliminate residual risks during normal operation.



Removal of the restrictions gives access to cold parts, hot parts and sharp edges.



When the electrical boxes and the electrical control panel are open, live parts can be accessed.



Instrument connection to the refrigerant circuit may cause the release of mildly flammable refrigerant.

Do not:

- remove or disable the safety guards;
- tamper with and/or modify, even partially, the safety devices installed on the unit.

In heat pump operation, during defrost cycles, the water drips onto the ground when the frost melts off the coils.

If the water is not properly drained, when the ambient temperatures are sub-zero, dangerous sheets of ice are formed.

Limit access to the area to prevent accidents.

2.5 Safety information on the refrigerant fluid

This product contains fluorinated greenhouse gases included in the Kyoto protocol. Do not release these gases into the atmosphere.

Type of refrigerant: R32.

GWP value: 677. Based on "IPCC Fifth Assessment Report".

GWP is the global warming potential.

The quantity of refrigerant fluid is indicated in the unit data label. Periodic inspections are necessary to check for refrigerant fluid leaks in accordance with local and/or European regulations.

The refrigerant fluid is classified in group 1 (hazardous fluids), pursuant to standard EN378, safety class A2L (mildly flammable). Refer to the local laws and regulations for unit installation with refrigerant fluid falling within this class.

2.5.1 Hazards and health consequences

If accidentally released, rapid evaporation of the liquid can cause freezing.

In case of contact with the liquid:

- defrost the various part with water;
- remove clothing carefully;
- rinse thoroughly with water.

Contaminated clothing and shoes should be washed before reuse.

High vapour concentrations can cause headaches, dizziness, drowsiness and nausea, and may lead to unconsciousness and cardiac arrhythmia.

If inhaled move the victim to fresh air. Artificial respiration and/or oxygen may be necessary. Call a doctor immediately.

In case of contact with eyes, remove contact lenses. Rinse immediately with plenty of water, holding the eyelids open, for at least 15 minutes.



The safety data sheet drawn up by the producer of the refrigerant can be obtained from the manufacturer of the unit.



The refrigerants used in these units are classified as ASHRAE A2L and they are characterised by low flammability (burning velocity < 10 cm/s). If refrigerant leaks out, it tends to stagnate in the bottom part of the area where the leak has occurred.

3 RECEIVING THE PRODUCT AND STORAGE

3.1 Reception

On receiving the unit, check that it is undamaged, bearing in mind that it left the factory in perfect condition.

Report any signs of damage immediately to the transporter and make a note of these on the Delivery Sheet before signing it.

The relevant sales department or the manufacturer should be informed of the extent of the damage as soon as possible.

The Customer must draw up a written and photographic report concerning any and all significant damage.

Disposal of the packing material is the responsibility of the consignee and must be carried out in compliance with the regulations in force in the country in which it is carried out.

3.2 Transport

The unit is sent from the factory using suitable vehicles, with correct locking in order to prevent any possibility of movement whilst in transit by road that may damage it or cause accidents.

If there is to be trans-shipment to other vehicles to continue the journey, it is essential to adopt all necessary measures for ensuring the correct safety conditions, with regard to the vehicles used and the anchorage, in order to prevent damage.

If the unit is to be transported over uneven roads, the manufacturer must be informed beforehand so that suitable measures can be taken in order to prevent damage to the unit.

If it is to be transported by container, make sure it is correctly anchored.

With reference to road, sea/ocean or air freight, refer to the ADR, IMDG, IATA codes, etc. in place at the time of transport.

Before organising the freight, the Manufacturer shall notify the quantity and type of refrigerant filled in the machine.



Units with mildly flammable refrigerants (A2L) shall be hauled in accordance with the European standards and regulations and the local regulations, where applicable.

3.3 Handling

Before each unit handling operation, check that the lifting capacity of the machinery used is compatible with the weight of the unit.

Handling must be carried out by adequately equipped qualified personnel.



In all lifting operations, make sure the unit is firmly secured in order to prevent accidental falls or overturning.



Lifting must be carried out by qualified and authorised personnel taking the necessary precautions; if carried out incorrectly, lifting can cause serious damage and physical injury.



The handling operations must be carried out slowly and sudden manoeuvres and knocks must be avoided.



Do not, under any circumstances, stand or pass under or near the unit when it is lifted off the ground. Use only the lifting system designed and prepared for the unit.

During unloading and positioning of the unit, great care must be taken to prevent sudden or violent manoeuvres, and the components of the unit must not be used as lifting points.

Make sure the machinery and lifting ropes are of suitable size and capacity and strictly follow their operating instructions. Use only equipment that is in excellent working order.

Check that the lifting equipment is of suitable size and capacity and strictly follow its operating instructions. Use only equipment that is in excellent working order.

All work on the unit, including unpacking and connections, must be carried out with the unit resting on the ground.

Refer, in any case, to the lifting instructions provided with the unit.

A pallet is secured under the unit so that it can also be unloaded and handled with a suitable forklift truck.

If anti-vibration mounts are installed under the base of the unit, this must be done with the unit raised by no more than 200 mm from the ground and without putting any parts of the body under it.

Before sliding out the pallet, remove the screws fixing it to the unit.

Use a 10 mm spanner to unscrew the screws that are visible through the slotted holes of the base.

Once the pallet has been removed, the unit must be lifted using only and exclusively slings and the yellow lifting brackets fixed to the base.

Use suitable shackles to fasten the slings to the lifting brackets.

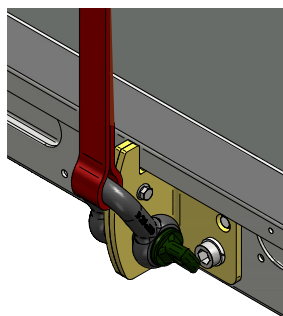

Fig. 2 Focus on the attachment of the sling to the lifting bracket



For lifting use all the brackets present in the unit.

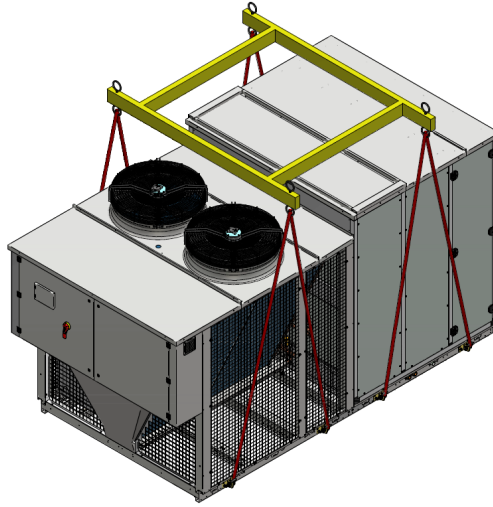

Fig. 3 Lifting with slings



To prevent the slings from touching the unit, suitable protective devices must be placed on the upper edges.

It is mandatory to use a lifting beam adjusted to the width of the unit in order to ensure lifting stability

4 PRODUCT DESCRIPTION

4.1 Intended use

These units are intended for cooling (unit in cooling only version) or for cooling/heating (heat pump version) of the air; they are generally used in applications in the air-conditioning field.

These units are intended for air cooling / heating, generally used in air conditioning applications

These are high efficiency, self-contained air conditioners, for both summer and winter use, that allow attainment of complete thermo-hygrometric air handling and recovery of the heat dispersed for air renewal. They can be used in both commercial and industrial applications that, besides having load variability, can be characterized by high latent loads and need to guarantee optimum conditions for occupants.

Their use is recommended within the operating limits indicated in the Technical Catalogue.

4.2 Unintended use

The unit must not be used:

- in an explosive atmosphere;
- in a flammable atmosphere;
- in extremely dusty environments;
- in an environment that is not compatible with the stated IP protection rating;
- by untrained personnel;
- in a way that does not comply with the regulations in force;
- with incorrect installation;
- with power supply defects;
- with total or partial failure to comply with the instructions;
- with lack of maintenance and/or use of non-original spare parts;
- with inefficient safety components.
- with modifications or other work not authorised by the Manufacturer.

4.3 Control and safety devices

The unit is integrally managed by an electronic microprocessor control that, through the various installed temperature and pressure sensors, keeps its operation within the safety limits.

All the parameters involved with control of the unit are shown in the "Control Manual" that is an integral part of the documentation of the unit.

All the parameters involved with control of the unit are shown in the "Operating Manual" that is an integral part of the documentation of the unit.

The manual fully describes the logic with which the checks of the unit take place during the various operating stages.

The control and safety devices are shown in the Technical Catalogue.

4.4 Principles of operation

The basic operation of these units uses a reverse vapour compression cycle to change the thermo-hygrometric conditions of the air in the interior environment. The simplest configuration works in total air recirculation.

The refrigeration cycle allows heat to be transferred from a fluid at a lower temperature to a fluid at a higher temperature. The Roof Top units are equipped with one or more refrigerant circuits; in cooling mode, air is cooled - and if necessary dehumidified - by a finned coil (evaporator); the removed heat is rejected to the outside by another finned coil (condenser).

In addition to this, the heat pump versions allow the evaporator and condenser roles to be reversed, thereby providing the heating function.

In addition to air filtration, other functions are possible, which vary depending on the configuration and the selected accessories: partial air renewal, heat recovery from expelled air, thermodynamic recovery, humidification, additional heating by means of burner, battery with hot water or electric heaters, free cooling / free heating.

4.5 Structure

Depending on the sizes, the structure is made of galvanized sheet-iron coated with epoxy polyester powder at 180°C, which makes it highly resistant to weather conditions, or of extruded aluminium alloy profiles connected with glass fibre reinforced nylon joints.

The base and cover are made of thick, epoxy polyester powder coated, galvanized sheet-iron.

The panelling is made with 25mm thick sandwich panels (50mm on request) consisting of a 0.5 mm thick externally pre-painted galvanized sheet-iron casing filled with polyurethane foam to guarantee the thermal and acoustic insulation of the unit. Alternatively, the panels are insulated with closed-cell insulating matting or with rock wool, for the "heat generator" section. The surface of the panels in contact with the treated air is made of galvanized sheet-iron to facilitate cleaning and sanitizing operations.

The non-removable panels are fixed to the structure with screws contained in nylon bushes with plug.

The removable panels are attached to the structure with nylon eccentrics or inserts and have handles to make them easier to remove.

4.6 Specifications

Direct expansion air conditioner with hermetic compressors, evaporating coil with centrifugal or radial fans and condensing coil with axial fans.

The unit is made in two sections that are joined together but functionally separate. One section is for transferring the energy absorbed from the treated interior environment into the atmosphere. The other section is for air handling and allows air conditioning of the confined environment to be treated.

In configurations where air exchange is envisaged, heat recovery and free cooling/free heating can be managed.

For heating, there may be a gas heat generator, or a hot water coil or a group of electric heaters.

4.7 Air system

4.7.1 Internal air fans

Depending on the configurations, there may be only supply fans or also return fans in the units.

The fans are radial fans with reverse blades, with external rotor motor directly coupled to the impeller.

The radial fans are called "EC", with electronically commutated brushless motor. The fan is powered by mains AC voltage, and speed control is obtained via DC 0-10V control signal coming from the microprocessor installed on the unit. This makes it possible to set the air flow rate through the parameter being displayed.

The motors have alarm signalling, which includes thermal overload protection, overcurrent, undervoltage, absence of one or more phases and seized rotor.



The EC fans are not provided with a contactor and are constantly live as soon as the main disconnect switch of the unit is closed.

4.7.2 Flow rate sensor for fans

Units with "EC" fans are provided with a differential pressure transducer that detects the pressure difference between the inside and the outside (upstream) of the intake nozzle. The air flow rate is proportional, for each fan/nozzle pair, to the square root of the pressure difference according to the equation:

$$Q = n \cdot k \cdot \sqrt{\Delta P}$$

where

- Q = total air flow [m³ / h]
- n = number of fans in the unit
- k = constant according to the fan nozzle
- ΔP = pressure difference measured on the nozzle [Pa]

The differential pressure value and the air flow rate can be shown directly on the display of the microprocessor that carries out automatic control of the air flow rate.

4.7.3 Dirty filter sensor (optional)

The level of air filter clogging is checked by means of a differential pressure switch that measures the pressure drop between upstream and downstream of the filter.

The control panel will signal, via an alarm on the display, the need to replace or clean the filter. The machine will continue to work in any case.

The cut-in value is factory set and can be changed on the installed unit by turning the knob with graduated scale using a screwdriver.



The fouling of the filter may cause a decrease in the flow rate and therefore of the machine's performance; restoring the filter as quickly as possible from the time of reporting is recommended.

4.7.4 Air filters

The units are fitted with filters on the air supply side. To replace the filters, open the panel of the unit that shows the indication for access to the filters.

Cleaning or replacement is essential to ensure good operation of the unit and the correct air flow rate.

4.7.5 Humidifier

The units can be equipped with an immersed electrode humidifier according to the model version. Before use, make sure all electrical and hydraulic connections have been made.

Should it be necessary to carry out maintenance or replace the humidifier components, first empty the water contained in the cylinder.

In order to ensure a correct operation and life of the humidifier cylinders, the characteristics of the feed water should be within the limits provided. The limits are reported in the specific manual.



Do not treat with softeners.

The use of well, industrial water or drawn from cooling circuits, potentially chemically or bacteriologically polluted, is forbidden. We do not recommend the addition of disinfectants or anticorrosive compounds, as they are potential irritants.

Any particular characteristics of the water supply, such as very low or very high conductivity, may require specific humidifier cylinders which differ from the standard, to be agreed upon with the manufacturer.

4.8 Control panel

The unit is fully managed by an electronic system with microprocessor that has a touch screen display as interface. By using the display, you can access all the unit's functions, such as visualising the operating parameters, setting the parameters, managing and analysing any problems.



Fig. 4 Main mask

Basic operations such as starting and stopping the unit, changing the set point and the status check of the operation, can be carried out easily.

For the other operations, refer to the manual of the control that is an integral part of the documentation of the unit.

The instructions below reference the main screen that is accessed from any other screen in the system by tapping the "Menu" icon, where provided, or the "Green arrow pointing left" icon.



"Menu" - pressing of this icon on the Home page gives access to the "Menu" screen. If this icon is pressed on any other screen, the system moves back by one level;



A click on this icon enables going back to the "loop" of the previous menu, gaining access to it with the active credentials.

4.8.1 Switch the unit on and off from the display.

Use the "On/Off" icon on the main screen to go to the page where the buttons to start and stop the unit are featured.

The top area of the screen shows the status of the unit: the "On/Off" icon is provided in the central area.

A tap on the icon changes the status of the unit from "on" to "off" and vice versa.

4.8.2 Switch the unit on and off from external OK signal

In order to switch the unit on and off from external OK signal, make sure the feature is active.

To switch the unit on, close the external OK signal. To switch it off, open it.

The external OK signal should be connected to terminals "1" and "2" present in the terminal board.



The external OK signal must be a potential-free contact.

4.8.3 Change of set points

The "Menu" icon provided in the main screen leads to the main menu page.

Go to the "Setpoint" sub menu and select the function whose setpoint is to be changed.

Scroll the parameters until the desired parameter setpoint is achieved.

Select the setpoint parameter to enable the edit keypad.

Set the new value and apply the green tick to confirm.

4.8.4 Time band setup procedure

Access to the screen where the time bands are set up requires entry of a password.

On the main mask press the "Menu" icon to access the main menu and then the "Parameters" menu.

Within the "Parameters" sub-menu, it is possible to access the function "ES - Energy saving" to set the parameters of the time schedules.

Select the desired parameter to activate the keyboard to change it.

Set the new value and apply the green tick to confirm.

4.8.5 Change language

On the main mask press the "Menu" icon to access the main menu, within the "Language" menu it will be possible to select the desired language among the available ones.

If the language you are looking for is not in the screen, use the arrows to find it.

The selected language becomes active as soon as it is selected.

4.8.6 Change date and time

Select "Date and Time" in the "Configurations" menu and access the screen where it is possible to edit the date and time setpoints.

Select the write icon in the bottom right-hand side to access the edit screen.

When a green value is tapped, a virtual keypad appears: use the keypad to set the new values. After entering the new value, tick it to confirm it.

After changing the values, tap the Save icon on the bottom right-hand side to save the new setpoints.

The arrow on the left is used to go back to the previous screen without saving the changed parameters.

4.9 Wiring diagram

The wiring diagram is an essential part of the documentation and is present inside each unit.

It is essential to refer to this document if you are unsure about anything or need further explanations regarding the auxiliary electrical connections and power connections as well as for the electrical specifications.

In particular, refer to the wiring diagram as regards the possibility of remotely managing the functionalities that contemplate this.

5 INSTALLATION

During installation or whenever work must be carried out on the unit, it is essential to strictly follow the instructions in this manual, comply with the directions on the unit and in any case take all necessary precautions.



The pressures in the refrigerant circuit and the electrical components can create risky situations during installation and maintenance work.

5.1 Dimensions and weight

In order to correctly position the unit, please refer to the dimensional drawing supplied with the order confirmation for its size and weight.

5.2 Installation site

The following should be taken into account to establish the best place to install the unit and the relevant connections:

- size and origin of the aeraulic ducts;
- size and origin of the hydraulic piping;
- location of the power supply;
- accessibility for maintenance or repair operations;
- load-bearing capacity of the support surface;
- ventilation of the air-cooled condenser;
- orientation and exposure to solar radiation. Keep the condensing coil out of direct sunlight as far as possible;
- direction of prevailing winds. Do not position the unit in a such way that prevailing winds can cause air recirculation at the condensing coil;
- type of surface. Do not position the unit on dark coloured surfaces (e.g. tarred surfaces) so as to avoid overtemperatures during use;
- possible reflections, resonances and acoustic interactions with elements outside the unit.



Pay attention to the presence of flues, drains, vents and to the stale air of other systems. Air can be sucked from the fresh air damper and through the supply unit in the rooms to be air conditioned.

All the models in the range are designed and built for outdoor installation (terraces, gardens). They must therefore not be installed under canopies or near plants (even if these would cover only part of the unit), in order to avoid the possibility of air recirculation.



It is obligatory to observe the clearances specified in the dimensional diagram of the unit.



If the unit is installed in particularly windy areas, windbreaks must be installed to prevent malfunctioning of the unit.



During the defrost cycle, units in heat pump operation allow water to flow out that freezes with sub-zero temperatures. Although the unit is installed perfectly horizontal, make slopes in the support surface to direct the defrost water into drains, wells or in any case to places where there is no danger of accident.



The unit is filled with refrigerant gas, classified as A2L (mildly flammable).

The unit must be installed in an area from which any leaking refrigerant cannot flow into buildings or cannot harm persons or damage property.

Similarly, should a refrigerant leak occur, the refrigerant must be prevented from flowing into fresh air inlets, doors or similar openings, and it must be prevented from building up under any walking surface and inside trap-doors.



any material exhausted from the safety valves must be conveyed using pipes in compliance with the national and/or European directives: the exhaust point must not be close to trap-doors, manhole covers and any other opening where refrigerant may be contained; Exhausted material must not be conveyed close to fresh air inlets, doors or similar openings.

Exhausted material must not be conveyed close to ignition sources, as defined in standard EN378-2.

It is the responsibility of the installer to carry out a flammability risk assessment and a classification of the danger zone at the site of installation, as required by standard EN378-3.

Where the existing local regulations are more stringent, these should be taken as reference.

5.3 Installation

The units are sent from the factory already tested and they need only the electrical, aeraulic and hydraulic connections for installation.

The only unassembled component shipped is the rain guard for units that envisage air exchange and are therefore equipped with external air damper.

5.3.1 External positioning

A solid base on which to position the unit must be created.

This base must be perfectly flat and horizontal. Its dimensions must be adequate for those of the unit.

The slab must be:

- made in a suitable foundation about 15-20 cm higher than the surrounding ground;
- flat, horizontal and able to bear at least 4 times the operating weight of the unit;
- at least 30 cm longer and wider than the unit.

Although the units transmit low levels of vibration to the ground, it is advisable to lay a strip of hard rubber between the base frame and the support surface.

If better isolation is required, it is advisable to use the anti-vibration mounts available as accessory.

In the event of installation on roofs or intermediate floors, the unit and pipes must be isolated from the walls and ceilings. The units should not be positioned near private offices, bedrooms or areas where low sound emissions are required.

It is also advisable not to install the units in narrow passages or small spaces, in order to avoid reverberations, reflections, resonances and acoustic interactions with elements outside the unit.

Units equipped with standard coils (copper-aluminium) should not be installed in an environment where there is an aggressive chemical atmosphere, in order to avoid the risk of corrosion.

Particular attention should be given to atmospheres containing sodium chloride, which worsen corrosion due to galvanic currents; a unit with untreated coils must absolutely not be installed in a marine environment.

For installations in marine environments, in the vicinity of animal farms or in heavily polluting industrial areas, it is necessary to order coils with anticorrosive surface treatments.

In any case, please contact our sales department to define the most suitable solution.

5.3.2 Fitting of rain hoods

A rain guard can be fitted on the opening for the passage of external air.

Protection is achieved with hoods; the number of elements forming the guard depends on the size of the air passage.

The guard is supplied in a separate kit for fitting by the installer.

In addition to the hoods, the kit includes a protective mesh and self-drilling screws for fixing.

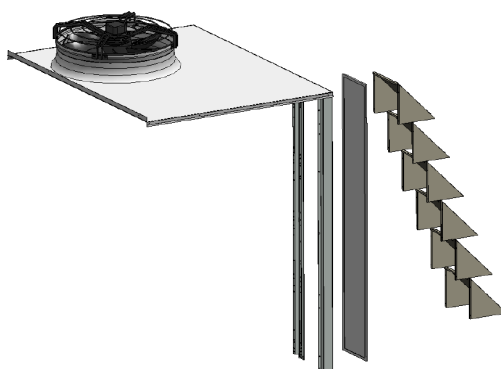

Fig. 5 Rain guard

The protective mesh is to be fixed between the guard and the frame of the unit and cover the entire opening. Use a 6 mm screwdriver with socket to fix it.

To fit correctly:

- Rest the mesh filter against the edge of the external air opening;
- begin fitting from the upper part of the opening;
- using the holes on each element of the guard, secure them to the frame of the unit with the self-drilling screws provided.
- repeat this operation for all the elements of the guard.

5.3.3 Anti-vibration mounts

In order to reduce vibrations transmitted to the structure, it is advisable to install the unit on rubber or spring anti-vibration mounts, supplied as an accessory and to be requested when placing the order.

The dimensional diagram with footprint shows the position and load of each anti-vibration mount.

The anti-vibration mounts must be fixed on before positioning the unit on the ground.

To install the anti-vibration mounts, see the instructions attached to the accessory.



When fixing the anti-vibration mounts, the unit should be lifted off the ground by no more than 200 mm and no parts of the body should be placed under the unit.

5.3.3.1 Rubber anti-vibration mounts

The anti-vibration mount consists of an upper metal bell in which there is a screw for fixing it to the base of the unit. The anti-vibration mount is fixed to the base through the two holes on the flange. The flange of the anti-vibration mount bears a number (45,60,70 ShA) that identifies the hardness of the rubber support.

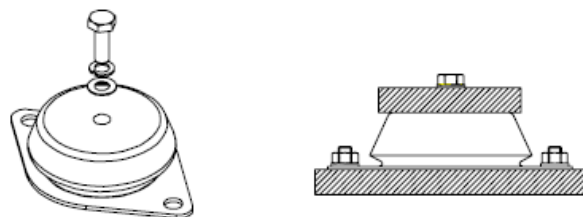

Fig. 6 Rubber/metal anti-vibration mounts

5.3.3.2 Spring anti-vibration mounts

The cylindrical spring anti-vibration mounts are suitable for isolating any source of mechanical vibration. Each anti-vibration mount bears a code that identifies the maximum load allowed.

It is very important to strictly comply with the assembly recommendations and instructions when installing the anti-vibration mounts.

Standard spring anti-vibration mounts: the frame of the unit is mounted on the anti-vibration mount with the through-screw and 2 washers.

Spring anti-vibration mounts for heavy loads: the load of the unit is borne by the entire surface of the anti-vibration mount and not just by the screw.

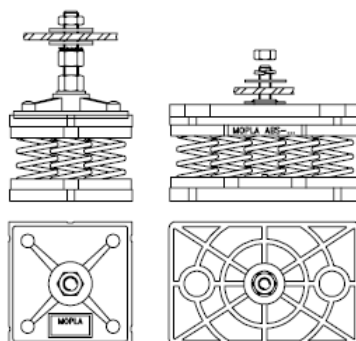

Fig. 7 Spring anti-vibration mounts

5.3.4 Noise attenuation

The units are designed and built paying particular attention to keeping down noise emission during operation.

In addition to standard versions, the company offers versions with the compressor compartment coated with sound absorbing material for lower noise emissions.

Correct installation for both the place and the components, as shown in the relevant chapter, avoids resonances, reflections and vibrations that can be particularly bothersome.

If, after following the instructions above, further attenuation is required, the use of acoustic barriers is a valid solution.

It is essential that any work done to soundproof the unit does not affect its correct installation or its correct operation.

That is why it is necessary not to restrict the service spaces and to avoid installing covers that create recirculation between air supply and intake.

5.3.5 Minimum distances

The service spaces to comply with are shown on the dimensional drawings attached to the documentation of the unit.

It is essential to ensure an adequate volume of air on the suction and delivery side of the condensing coil.

It is very important to avoid recirculation between suction and delivery, as this would lower the performance of the unit or even stop its normal operation.

The presence of very high walls near the unit will impair its correct operation.

Units should be installed a minimum of three metres apart.

It is advisable to leave sufficient space between units to allow their larger components, such as heat exchangers and compressors, to be removed if necessary.

5.4 Hydraulic connections



If the unit has parts that require a hydraulic connection to be carried out by the installer, it is mandatory to fit a metal mesh filter with mesh size no larger than 1 mm on the inlet pipes. If this is not installed, the warranty is voided immediately.

5.4.1 Hot water coil connection



The use of muddy water or water with a high limestone content can cause a rapid decline in coil performance.



Connect the hot water coil following the inlet and outlet indications shown on the unit.

The diameters and types of connection required are indicated in the dimensional drawings.

It is advisable to feed the coil with a water-glycol mixture at a percentage that depends on the minimum winter temperatures to prevent freezing of the water inside the hydraulic circuit when it is not being used.



If a water and glycol mixture is not used, the hydraulic system must be emptied whenever it is to remain unused for a long time.

To make the circuit emptying operations easier, there is a drain valve on the underside of the manifold that feeds the hot water coil. This manifold also has an air valve at the top that can be used to eliminate any air pockets there may be in the circuit.

The glycol percentage by weight is determined based on the envisaged minimum ambient temperature.

Minimum ambient temperature (°C)	0	-5	-10	-15	-20	-25	-30	-35	-40
Freezing point (°C)	-5	-10	-15	-20	-25	-30	-35	-40	-45
Antifreeze	% by weight								
Ethylene glycol	6	22	30	36	41	46	50	53	56
Propylene glycol	15	25	33	39	44	48	51	54	57

5.4.2 Condensate drain of the internal air coil

The condensate collection tray is provided with a male R 1" threaded pipe for connection.



Fig. 8 Connection to the condensate collection tray

On the condensate discharge pipe it must be installed a proper syphon in order to avoid that outdoor air may be blown through it.

It is good practice to make a syphon straight after the connection to the tray.

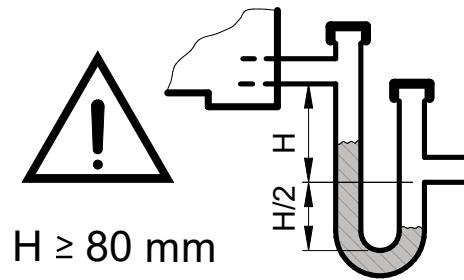

Fig. 9 Syphon for condensate discharge pipe.

The pipe draining the condensate must never be connected to waste water drains or run-off water drains, only to rainwater systems to prevent any foul smelling gases from being sucked back.

5.4.3 Condensate drain of the external air coil

The condensate collection tray is provided with a male R 1" threaded pipe for connection.



Fig. 10 Connection to the condensate collection tray

The condensate drain of the external air coil can be left free.



Any condensate pipework connected to the unit must be protected from freezing.

5.4.4 Connection to the humidifier

Where present, the humidifier must be supplied with untreated mains water, preferably filtered from impurities and / or waste. The diameters of the couplings are reported in the dimensional drawings.

We recommend that the drain duct should consist of a non-electrically conductive material.



The water discharged from the humidifier can reach 100 ° C.



It is compulsory to implement a syphon in order to drain the water from the humidifier.



Absolutely do not fill the humidifier with demineralised or softened water.

Further information regarding its installation are reported in the chapter "Humidifier".

5.5 Electrical connections

All electrical operations must be carried out by personnel having the necessary legal requirements, and trained and informed on the risks connected with these operations.

The sizing and characteristics of the power lines and relevant components must be determined by staff qualified to design electrical systems, following the international and national regulations of the place of installation of the units in conformity with the regulations in force at the time of installation.

To install components outside the unit, you must refer to the wiring diagram supplied with the unit.

The wiring diagram, along with the manuals, must be kept carefully and made available for future work on the unit.

Overview:

- The electrical connections must comply with the information shown in the wiring diagram attached to the unit and the regulations in force in the place of installation.
- grounding is required by law;
- the installer must connect the ground cable with the appropriate PE terminal on the ground bar located in the electrical panel as specified in paragraph 8.2.6 of the EN 60204-1 standard.
- Make sure the power supply voltage corresponds to the rated data of the unit (voltage, number of phases, frequency) stated on the plate on the unit.
- the standard power supply voltage (see specific wiring diagram) must not fluctuate by more than $\pm 10\%$ and the unbalance between phases must always be less than 2%. If this does not occur, contact our technical department to choose suitable protection devices.
- The standard supply voltage (see specific wiring diagram) must not fluctuate by more than $\pm 10\%$ and the unbalance between phases must always be less than 2%.
- The control circuit power supply is taken from the power line via a transformer situated in the electrical control panel; the control circuit is protected by fuses.
- Make sure the power line is correctly connected with a clockwise phase sequence.



This equipment complies with IEC 61000-3-12, regarding limits for harmonic currents, provided that the short-circuit power S_{sc} , at the interface point between the user's supply and the public system, is greater than or equal to the value reported in the wiring diagram provided with the unit.

It is the responsibility of the installer or user of the equipment to ensure, by consultation with the distribution network operator if necessary, that the equipment is connected only to a supply with a short-circuit power S_{sc} greater than or equal to the value reported in the wiring diagram provided with the unit".

To connect the unit to the power supply, a metallic blind flange has been foreseen on the lower part of the electrical cabinet

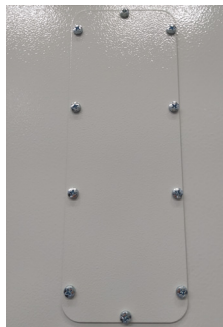

Fig. 11 Blind flange for the connection to the power supply (view from the bottom of the electrical cabinet)

To pass with the power supply cable, it is possible to disassemble and drill the required holes on the flange in order to assembly the proper cable glands.



To fix the power cable, use power cable fixing systems that resist tensile and torsional stresses. The weight of the cables must not be borne by the electrical connection system.



The cross-section of the cable and the line protection devices must correspond to those indicated in the wiring diagram.



The connections to the electrical control panel must be made maintaining the stated IP protection rating.

A phase sequence and minimum/maximum voltage relay, with three led, is mounted in the electrical cabinet.

The green led light means that the power supply is properly connected and so the relay is closed.

The yellow led blinking quickly with a long pause means that one phase is missing (the relay is open).

The yellow led blinking quickly with a short pause means that the phase sequence is wrong (the relay is open).

The red led blinking quickly with a short pause, together with the green led lighted, means that the supply voltage is out of the limits (the relay is closed).

The red led blinking slowly means that the alarm due to the low voltage is active (the relay is open).

The red led continuous light means that the alarm due to the over voltage is active (the relay is open).



Fig. 12 Phase sequence relay

To pass with the power supply cable, it is possible to disassemble and drill the required holes on the flange in order to assemble the proper cable glands.



The contact of the phase sequence relay cuts off the 230 V power supply and therefore the controller will in any case be powered, but the fans and compressors will not start.



Make sure no voltage is present before carrying out any operation on electrical parts.



If you use a residual current device to protect the power line, in units with inverter, use type "B" or "B+" residual current devices, with minimum tripping threshold of 300 mA and delayed tripping.



The electrical connections to potential-free contacts, which are powered by external sources, must be suitably protected against overcurrent and earth faults.

The circuit of the potential-free contacts inside the electrical control panel is made using orange cable.

5.6 Aeraulic connections

The ducting must be suitably sized so as not to generate unforeseen concentrated and/or distributed head losses that can cause drops in the handled air flow rate below the design flow rate. The head losses in the ducting must not exceed the available pressure provided by the fans (for particular applications, consult our Technical Department).



The ducts connected to the appliance shall not contain any potential ignition source as defined by IEC 60335-2-40:2018.

5.6.1 Return and supply ducts

The units have provision for various connections of both the return duct and the supply duct.

To identify these, refer to the dimensional drawing present in the documentation of the unit.

For the connection, the closing panels with which the unit was shipped must be removed.

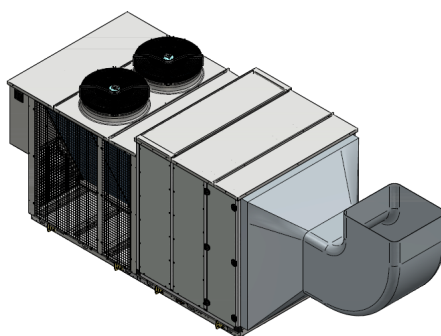

Fig. 13 Connection of return duct

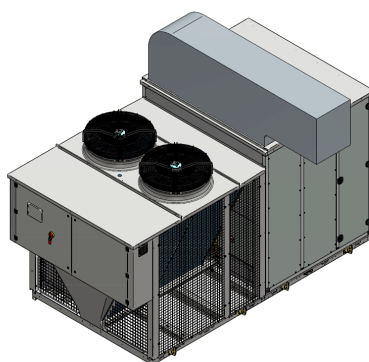

Fig. 14 Connection of supply channels

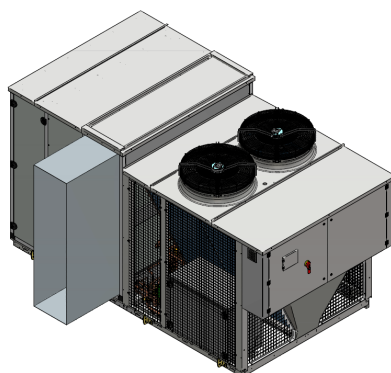

Fig. 15 Side connection

If the supply is downward, the panel on the bottom of the unit must be removed

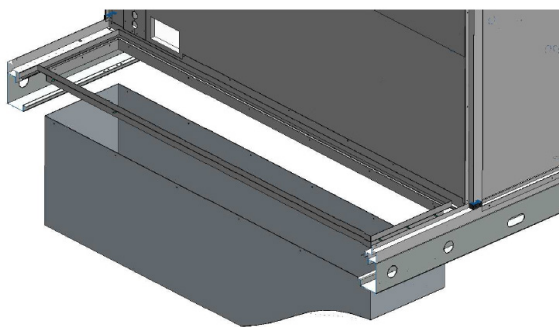

Fig. 16 Downward connection

5.6.2 Connection of the ducts

Correct installation of the channels should comply with the following recommendations:

- the size of the ducting must be at least the size of the supply outlet and suction inlet on the unit. It is preferable to enlarge the ducts near the machine made in accordance with the rules of good practice;
- the ducting must be connected to the unit by interposition of an anti-vibration coupling in order to reduce transmission of vibrations from the unit to the ducting;
- always seal the joints so as to prevent air escaping from the channels;
- avoid making the ducts make sharp bends or branches in the immediate vicinity of the unit, in particular as regards the air delivery duct where two coupled fans are installed.
- if the noise transmitted by the machine through the channels needs to be considerably reduced, these must be fitted with special silencers. The pressure drops along them must be considered when calculating the required available external head pressure.
- if the unit is equipped with a direct exchange heat generator, the supply channel must be provided with a special fire damper as laid down by current regulations.

6 COMMISSIONING

6.1 Preliminary operations



The unit should only be started up by qualified personnel authorised by the manufacturer.



All the units are pre-charged with refrigerant gas, so the refrigerant circuit is pressurised.



The unit is filled with refrigerant gas, classified as A2L (mildly flammable).

Check:

- that the electrical connection has been made correctly and that all terminals are properly tightened;
- that the voltage on the RST terminals is $400\text{ V} \pm 10\%$ (or the rated voltage of the unit if there are special voltages). If frequent voltage fluctuations are experienced, contact our engineering department in order to choose suitable protective devices.
- that the gas pressure in the refrigerant circuits is shown on the pressure gauges (if present) or on the control display;
- that there are no refrigerant fluid leaks, using a leak detector if necessary (the presence of oil stains may be a sign of refrigerant leaks).



Be careful with the electrical checks and use only suitable tools.

Position the master switch of the unit to ON and check on the display of the control that the unit is OFF in order to prevent it from starting.

Check that the heaters for heating the oil in the compressor crankcases are powered correctly.



The crankcase heaters are switched on when the main disconnect switch is closed and this must be done at least 12 hours before starting the unit.

To check that the heaters are working correctly, check that the lower part of the compressors is hot and in any case at a temperature of 10 - 15 °C above ambient temperature.

Check:

- that any sensors supplied with the unit are installed correctly according to the wiring diagram and the relevant documentation;
- that the remote control, if any, is connected as shown in the wiring diagram and that it is working correctly;
- that the connection to the aeraulic system has been made correctly, via the air supply and return channels;
- that the hydraulic connections have been made following the instructions on the inlet/outlet plates and that a mechanical filter has been installed at the inlet of the unit (failure to install this mandatory component will void the warranty);
- that the hydraulic system has been bled, to remove any remaining air, by filling it gradually and opening the bleed devices including the one on top of the coil;
- that a suitable syphon has been made on the condensate drain.



If the unit has a gas burner, follow the relevant instructions attached to the unit.



Before starting the unit, check that all the closing panels of the unit are in place and secured with fixing screws.

6.2 First starting

6.2.1 Preliminary checks



To operate, the unit must have the external OK signal input closed.

Refer to the wiring diagram supplied with the unit for connection of the external OK signal input. If it is not necessary for system requirements, the external OK signal input must be short-circuited. For this purpose, a cable is already foreseen and partially connected to the contacts.



The cable is already connected on the clamp "2"; To complete the bridge connect it to the clamp "1".

6.2.2 Functional tests

The main ventilation system will start a few seconds after the unit has started.

The starting of the compressors depends on the thermoregulation request and on possible activation of the air exchange on starting the washing function.



When the washing function is active, it's stop can be forced.



This icon on the top of the main screen means that the washing function is active.

Washing function can be stopped through the dedicated button reachable by pushing on the washing icon.

Check that the absorption of the motors of the main ventilation system is within the rated value. Higher values indicate an excessive air flow rate that, if it continues, can cause the electrical protection devices of the motors to cut in.

Check that the values measured by the sensors of the control (temperatures, pressures) correspond to the real values.

The unit automatically controls the ventilation airflow, check on the unit display that the desired setpoint has been reached. Lower readings of the airflow may be due to excessive pressure drops within the aeraulic circuit.

After a few hours of operation of the compressors, check that the liquid sight glass has a green ring: if it is yellow, there is moisture in the circuit. In this case, the circuit must be dried by qualified authorised personnel.

Check that bubbles do not appear at the liquid sight glass. The continuous passage of bubbles can indicate there is insufficient refrigerant and it needs to be topped up. However, the presence of a few bubbles is allowed.

It is mandatory to keep a register for the unit (not supplied), which allows you to keep track of the work carried out on the unit. This will make it easier to appropriately organize the work to facilitate the checks and the prevention of malfunctions.

State the following in the register: the type of refrigerant, the date and type of work done (routine maintenance or repair), description of the work with any parts replaced, measures implemented, the operator who carried out the work and his qualification.

6.3 Calibration of safety components



Any work on the unit must be carried out by qualified authorised personnel. Incorrect calibration values can cause serious damage to the unit and harm people.

The control and safety equipment is calibrated and tested in the factory before the unit is shipped.

However, after the unit has been started, the safety devices must be checked (only the high pressure switches).

The checks must be carried out as described in the "Periodic checks" chapter.

The calibration values are shown in the table

Control and safety components	Activation set point	Differential	Reset
High pressure switch for 2.1	42,0 barg	8,0 barg	Manual
High pressure switch for all the others	44,0 barg	8,0 barg	Manual
High pressure safety valve (where present)	46 barg	-	-

6.4 Checks during operation

With the circuits operating at 100% and stable at working conditions near the nominal ones, check:

- that the electrical absorption of the unit is close to the data shown in the wiring diagram. Considerably different values may be due to the reduced capacity operation of the unit, to working conditions very different from the nominal ones or to the malfunctioning of one or more components.
- that the difference between the condensing temperature of each circuit and that of the air is less than 25°C. If it is greater, check that all the fans involved are turning correctly and that there are no obstructions or dirt on the surface of the condensing coil;
- the superheating value of the suction gas: the optimal value is between 4 and 7°C;
- the subcooling value of the liquid leaving the condenser: the optimal value is between 5 and 10°C;
- that the liquid sight glass is green;
- that no bubbles appear on the sight glass placed in the liquid pipe. The continuous presence of bubbles may indicate a lack of refrigerant charge; the occasional or sporadic presence of bubbles is allowed;
- that the refrigerant filter is not blocked or clogged. To this end, it is sufficient to measure the temperature of the liquid pipe immediately before and immediately after the filter, and check that there are no significant differences (up to a couple of degrees C difference is allowed).
- that the condensate drain is working correctly.

6.5 Alarms and malfunctions

Possible malfunctions will trigger the protective devices and safety devices of the unit before serious faults occur. All the “warnings” and “alarms” are recorded in the memory of the control and displayed on the display of the unit.



Before resetting an alarm, the cause that triggered it must be found and eliminated.
An alarm going off repeatedly quickly leads to serious damage to the unit.



Unit filled with refrigerant classified as A2L (mildly flammable) A refrigerant leak alarm identifies the potential formation of flammable atmospheres.

Refer to the manual of the control for the alarms and warnings that appear on the display of the unit.

In case of anomalies not handled by the control panel, refer to the following troubleshooting section.

This troubleshooting section does not include causes due to deliberate work or tampering or particularly serious malfunctions, for which a thorough analysis is necessary.

6.5.1 General troubleshooting

SYMPTOM	LIKELY CAUSE	POSSIBLE SOLUTION
The unit does not start, the display is off.	No mains voltage.	Check that the main disconnect switch is in the “ON” position. Check for voltage in the power supply line.
	No voltage to the auxiliary circuit.	Check that the protective devices upline and downline of the transformer of the auxiliary circuit are undamaged. Reset the triggered protective device after eliminating the cause that triggered it
The unit does not start, the display is off, the control is powered correctly.	The unit is switched off from the display and the display is disconnected or not working.	Restore the connection of the display or replace it.
The unit does not start, the display is off, the control is powered correctly but the LEDs are not flashing.	The control is not working.	Replace the control.
The unit is operating normally, the display is off.	The connection of the display to the control is disconnected.	Restore the connection between the display and the control.
	The display is not working.	Replace the display.
The unit does not start, the display is on.	There is no 230V auxiliary power supply.	Check that the secondary circuit of the 230V transformer is intact.
		Check that the protective devices downline of the 230V transformer are intact.
		Check that the phase sequence is correct and that the phase sequence relay is intact.
Abnormal noises from the unit due to vibrations.	The weight of the unit is not distributed evenly on the base.	Correct the weight distribution of the unit by adjusting the height of the anti-vibration mounts.
Abnormal noises on the hydraulic pipes.	Operation of the system pump outside its performance curve with excessive water flow rate.	If it is not possible to work on the control of the pump, partially close the shut-off device on the delivery side of the unit until the nominal flow rate is restored.
		Check that the air valves are not shut off by valves. Vent the system.
	Presence of air in the system.	

SYMPTOM	LIKELY CAUSE	POSSIBLE SOLUTION
Presence of oil on the discharge of the safety valve.	Opening of the valve due to failure of the protective devices to operate.	Check that the high pressure switches are working and, if necessary, replace them. The valve must be replaced.
	Opening of the valve due to overtemperature.	Replace the valve and restore the charge.

6.6 Temporary stop

The shutdown of the unit for a few days is considered as temporary.

The unit must be stopped using the display of the control, the external OK signal or via serial if included.

During the temporary stop, the unit must be powered correctly.

When the temporary stop is carried out in this way, all that needs to be done to restart the unit is to set the control to "ON".

6.7 Stop for long periods of time

When the unit is not used for months this is considered a long period shutdown.

Should the unit be expected to stop for long periods, it is necessary to:

- turn the unit off by means of the control switch;
- disconnect the power supply using the switch / general switch of the unit;
- drain the hydraulic system (unless it uses glycol water);
- empty and clean the condensation drip tray;
- empty the humidifier cylinder if present;
- Check that fresh and exhaust air dampers, if present on the unit, are completely closed.

This case record can in fact be traced back to the storage condition; therefore, refer to the relevant set limits.

Repeat the start-up procedure at the next restart.



Follow the new start-up procedure and replace the cartridge of the leak detection system.



All operations required on the unit for the purpose of maintenance must be carried out by authorised and qualified staff, as described by Annex HH of IEC 60335-2-40:2018, by local legislations and, with respect to european standards, by EN 378-4 and EN 13133.



Before work is started on the unit: check for potentially flammable atmospheres; check for possible ignition sources.

7 MAINTENANCE



All operations required on the unit for the purpose of maintenance must be carried out by authorised and qualified staff, as described by Annex HH of IEC 60335-2-40:2018, by local legislations and, with respect to european standards, by EN 378-4 and EN 13133. Take Annex E to standard EN378-4 as main reference.



Unit filled with refrigerant classified as A2L (mildly flammable) A refrigerant leak alarm identifies the potential formation of flammable atmospheres.



Before carrying out any work on the unit or accessing internal parts, make sure you have turned off the power supply to it.



The compressors and delivery pipes are very hot. Be particularly careful when working near them.



Be particularly careful when working near the finned coils as the aluminium fins are very sharp.



Do not access moving parts without guards.



In units with capacitors and/or inverters, certain components can remain live for several minutes even after having turned off the main switch.

Wait 10 minutes before working on the electrical parts of the unit.



Circuits supplied from external sources (made with orange cable) can remain live even after the power supply to the unit has been turned off.



Work on the unit only if there is sufficient lighting for the type of work to be carried out.

7.1 Adjustments

All the parameters that control the operation of the unit can be set through the user interface of the control.

Refer to the control manual should modifications be necessary, but contact the manufacturer first.

Calibrations regarding the safety of the unit cannot be modified (safety valves, high pressure switches, fuses, etc.) or are in any case protected from tampering (calibration of thermal overload protection devices, timers, etc.).

If in any case replacement becomes necessary, it is essential to use components supplied by the manufacturer (in the case of adjustable parts) or with the same sizes and characteristics (in the case of fuses).

7.2 External cleaning

The component of the unit that needs most care is the finned pack heat exchanger.

It is essential to keep it clean and free of dirt and/or deposits that can hinder or prevent air flow.

Regular cleaning of the surface of the coil is essential for the unit to work correctly and also increases the operating life of the exchanger and the unit.

Frequent and correct cleaning of the coils contributes to considerably reducing corrosion problems.



While cleaning the finned packed heat exchanger, the electrical control panel must be closed and the main disconnect switch must be locked in the "OFF" position.



Using a jet of water on the coil while it is still dirty will cause deposits and pollutants to remain inside the exchanger, which will make cleaning even more difficult. All the dirt and deposits must therefore be removed from the surface before rinsing.



For units installed in coastal or industrial areas or in areas where there are aggressive chemicals in the air, periodic rinsing with clean water is considerably beneficial and helps counter corrosive effects.



Never clean the coils with chemicals, water containing bleach or acid or basic detergents. These detergents can be difficult to rinse off and could accelerate corrosion on the joint between pipe and fin and in areas where different materials come into contact (Cu and Al).

7.2.1 Cleaning traditional finned coils in Cu/Al

Conventional pipe-fin coils can be cleaned with a vacuum cleaner or a brush with soft, non-metallic bristles.

Always clean in the direction of the fins and never perpendicularly to them. They can easily be bent and damaged.

Clean in the opposite direction to the normal air flow.

The coil can then be rinsed using only drinking water at low pressure (3-5 barg).



Rinsing must be carried out with a low pressure jet of water to avoid damaging the fins.

Never use jets of water or high-pressure compressed air to clean the coil. The force of the jet of air or water could bend the fins, with a consequent increase in aeraulic head losses on the exchanger and lowering of the performance of the unit.

7.2.2 Installation site cleanness

Keep the place where the unit is installed clean and tidy so that its parts can be reached safely. In particular, avoid the accumulation of leaves and dirt near the unit or the deposit of materials that may give off bad smells or irritant substances that can be put into the room with the fresh air.

Dust emission and dirt near the unit cause a rapid decline in the efficiency of the air filter present on the supply line.

7.3 Internal cleaning

It is essential to keep the installation site clean and tidy for correct maintenance of the unit and to keep it in good working order.

7.3.1 Cleaning the unit

Keep the inside of the electrical control panel and (where present) the compressor compartment clean.

After working on the unit, always clean the electrical control panel of any work remnants and extraneous components.

Restore the safety devices and protective devices that had to be removed in order to carry out the work.

Use a vacuum cleaner to eliminate small objects, work remnants and/or any dust.



Do not use compressed air

If you have to carry out work on compressors inside the compartment, before closing it again, check that the electrical box of the compressor is closed correctly and that any refrigerant circuit valves are in the correct state, and make sure you do not leave any materials inside the compartment.

7.4 Periodic checks

Carry out periodic checks to make sure the unit is working correctly:

OPERATION	RECOMMEN- DED FREQUEN- CY
Check the operation of all the control and safety equipment as described previously.	Monthly
Check the tightness of the electrical terminals in the electrical control panel and in the terminal boards of the compressors. The moving and fixed contacts of the contactors must be cleaned periodically and should be replaced whenever they show signs of deterioration.	Monthly
Check the refrigerant charge through the liquid sight glass.	Monthly
Make sure there are no oil leaks from the compressor.	Monthly
Make sure there are no water or water/glycol mixture leaks in the hydraulic circuit.	Monthly
If the unit is to remain out of service for a long time, drain the water from the pipes and the heat exchanger. This operation is necessary if ambient temperatures lower than the freezing point of the fluid used are expected during the time it is to remain stopped.	Seasonal
Check the filling of the water circuit.	Monthly
Check that the differential water pressure switch, or the flow switch (where present), is working correctly.	Monthly
Check the crankcase heaters of the compressors.	Monthly
Clean the finned coil by following the instructions in the "External cleaning" section according to the type of coil installed	3 months
Clean the air filters	Monthly
Clean the ventilation filters of the electrical control panel.	Monthly
Carry out the defrosting test (only for heat pump units).	Monthly
Carry out the defrosting test.	Monthly
Check the moisture indicator on the liquid sight glass (green = dry, yellow = wet). If the indicator is not green, as indicated on the sight glass sticker, replace the filter.	4 months
Check the condition, fixing and balance of the fans.	4 months
Check that the noise emitted by the unit is normal.	4 months
Test performed to check correct operation of the refrigerant leak detection sensor and its safety chain connected downline	Yearly
Check that the cable glands in the box of the electrical control panel are tightened.	Yearly
Replacement of the refrigerant leak detector sensor	10 years



This planning refers to an average installation; there could be installations in which it may be necessary to increase the frequency of some checks.



Current legislation may require considerably longer intervals on periodic checks than the recommended ones, also in reference to the safety devices installed and to the refrigerant charge present, without causing the warranty on the unit to be voided.

7.5 Unscheduled maintenance

After correctly starting-up and carrying out the relevant checks, the units normally do not need any intervention by the customer service in order to check the charge of the refrigerant gas.

7.5.1 Special work

With use of the unit, particular situations may occur that require work to be carried out promptly.



Any work performed on the unit in the event of an emergency must be carried out in safe conditions and by authorised and qualified staff, as described by Annex HH of IEC 60335-2-40:2018, by local legislations and, with respect to european standards, by EN 378-4 and EN 13133.

The presence of oil on the unit, on the pipes or on parts of the unit can be a sign of gas leaks.

Repair the leakage point and restore the charge of refrigerant gas.

In the case of small oil leaks, clean the dirty parts with absorbent cloths, otherwise recover the leaked oil with absorbent sheets. In any case, the material used must be disposed of in accordance with current rules and regulations.

Check whether it is necessary to restore the oil charge.

In the case of spillage of the water and glycol mixture of the system, stop the operation of the unit and immediately stop the supply by closing the valves to isolate the leaking part.

Prepare suitable means for containing the spillage (absorbent rolls, cloths, sheets).

As far as possible, recover the liquid with a wet vacuum cleaner.

In the event of environmental damage that will require reclamation work, inform the relevant authorities.

The recovered liquid and the material used must be disposed of in accordance with current rules and regulations.

8 DECOMMISSIONING

With reference to the European waste management directive, we inform you of the following:

- The owner of electrical and electronic equipment (EEE) is obliged not to dispose of it as non-separated municipal waste, and must dispose of it via separate collection through public or private waste collection systems as required by local regulations.
- The owner can return EEE to the dealer at the end of its life when purchasing equivalent new equipment.

This EEE may contain hazardous substances such as refrigerant gases, lubricating oils and accumulators or other materials, and improper or incorrect disposal of them may have adverse effects on human health and the environment.

Incorrect disposal of them also entails penalties as provided for by local regulations.

The symbol shown on the equipment, which indicates separate collection of EEE, is a crossed out wheellie bin accompanied by a solid horizontal bar and identifies that it was put on the market after 13 August 2005.



Page intentionally blank

Page intentionally blank

Page intentionally blank

Page intentionally blank

